

A46JRTE

ELECTRIC ARTICULATED BOOM LIFT



- Zero emission electric rough terrain articulated boom lift with lithium-ion batteries
- Powerful 4-wheel drive for rough terrain
- Highly manoeuvrable with tight turning radius
- Superb working envelope with zero tailswing
- Robust, reliable and easy to operate



snorkel[™]

www.snorkellifts.com

ELECTRIC ARTICULATED BOOM LIFT

A46JRTE

DIMENSIONS	A46JRTE
Max. working height	16.3m
Max. platform height	14.3m
Max. working outreach	7.35m
Clearance height at max. outreach	7.67m
Platform size	1.0m x 1.83m
Chassis width (A)	2.1m
Overall length (B)	5.7m
Stowed height (C)	2.16m
Ground clearance	330mm

PERFORMANCE	
Platform capacity (SWL)	227kg
Max. drive height	14.3m
Max. wind speed	12.5m/s
Max. drive speed (stowed)	6.4km/h
Max. drive speed (elevated)	1.3km/h
Jib length	1.5m
Jib arc	140°
Platform rotation	160°
Turret rotation (non-continuous)	360°
Tailswing	0m
Raise/lower time	101/98 sec
Gradeability	45%
Inside turning radius	0.8m
Outside turning radius	3.1m
Tyres	High grip, foam-filled 355/55D625NHS 17.5
Controls	proportional
Drive system	4-wheel drive

POWER	
Power source	17.25kWh Li-ion batteries with integrated BMS
Operating temperature	(-) 25°C to (+) 60°C
Charger	high frequency smart on-board 50A battery charger

MOTOR	
Motor	AC electric motor

WEIGHT	
Weight	7,540 kg

WORKING ENVELOPE

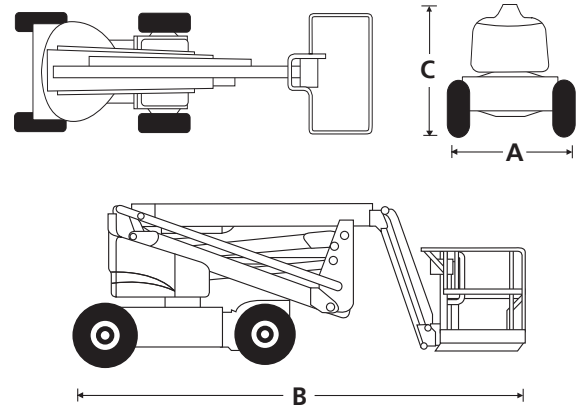
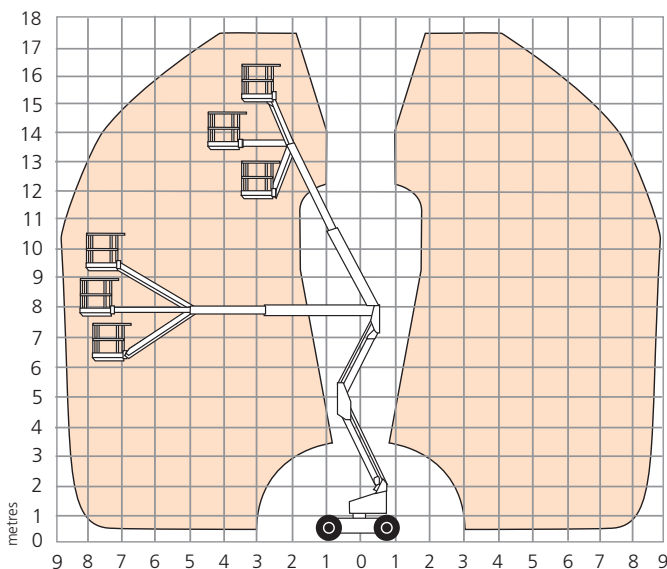

STANDARD FEATURES

- Three lithium-ion battery systems 17.25kWh
- Snorkel Guard™ secondary guarding system
- Tri-entry platform
- Drive motion alarm
- Multi-function proportional controls
- Oscillating front axle
- Power line to platform
- Zero tailswing
- Hour meter & on-board diagnostics display
- Non-marking foam filled tyres
- 2000 charging cycles/2 year** lithium battery warranty
- 2 year parts & labour, 5 year structural warranty
- CE approved

OPTIONS

- Special paint colours
- Airline to platform
- Additional 5.75kWh battery system
- 1.52m aluminium platform with swing gate
- Environmental hydraulic oil
- Tool tray
- Aircraft package
- Deluxe aircraft package
- Extreme environment package
- Light package
- Utility package
- Snorkel OnSite™ telematics



www.snorkellifts.com

Vigo Centre, Birtley Road,
Washington, Tyne & Wear,
NE38 9DA, U.K.

t: +44 (0) 845 1550 057

e: sales.emea@snorkellifts.com